

THIS DRAWING IS UNPUBLISHED. RELEASED FOR PUBLICATION  
 © COPYRIGHT BY TYCO ELECTRONICS CORPORATION. ALL RIGHTS RESERVED.

LOC	DIST	REVISIONS					
		P	LTR	DESCRIPTION	DATE	DWN	APVD
G	14		M	REV PER 0G3A-0832-04	28JAN05	JR	TM

<b>AMP</b> WIRE RANGE	Listed FILE E13288	LR7189 Certified
16-14 AWG SOLID OR STRANDED	16-14 AWG SOLID OR STRANDED	16-14 AWG SOLID OR STRANDED

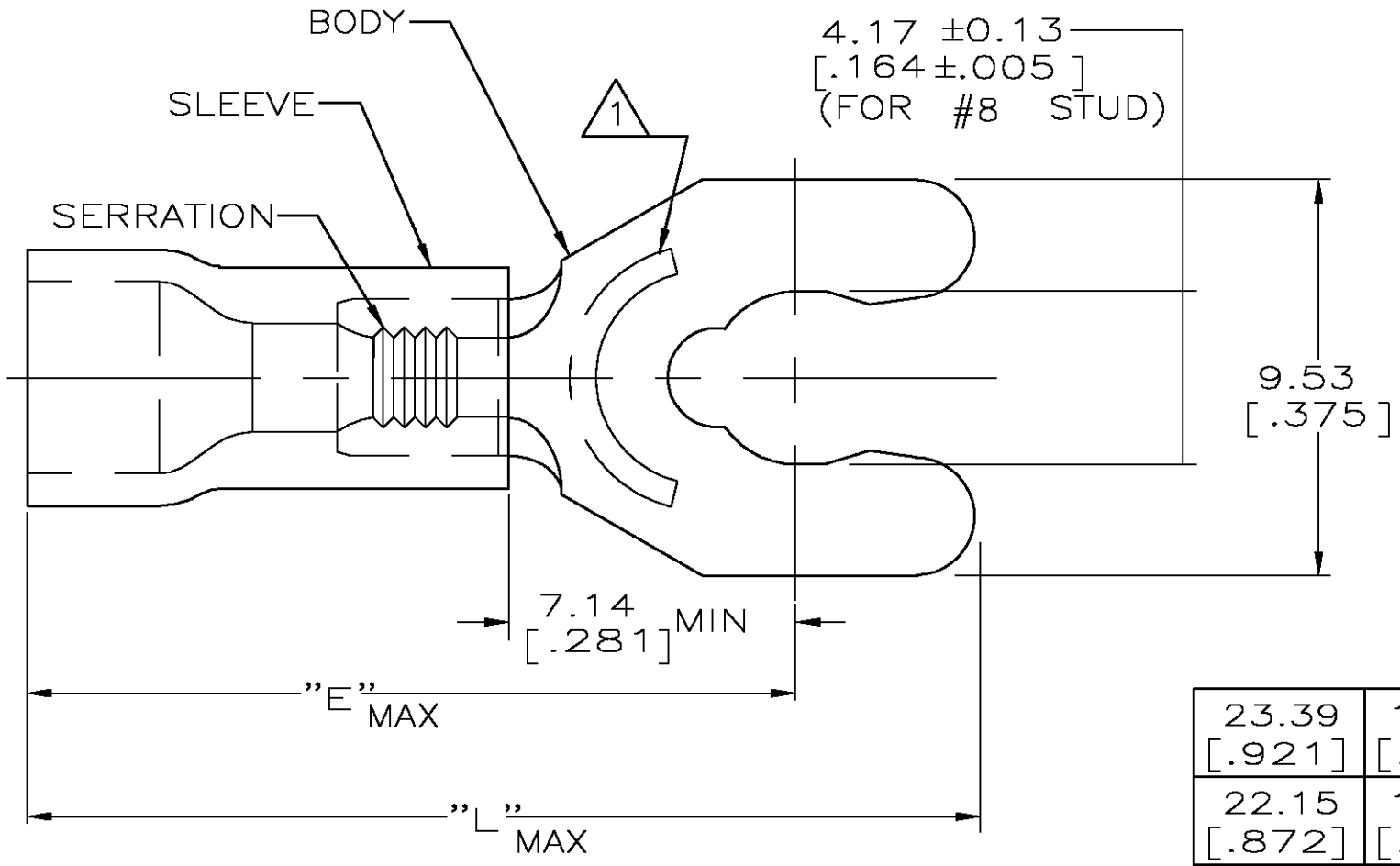

- △ 1 STAMP 8SAMP 16-14\* APPROX AS SHOWN
- 2. SEE TABLE FOR WIRE INSUL DIA
- 3. TONGUE MATL THK, 0.79±0.05 [.031±.002]
- △ 4 MATERIAL: BODY - BRASS PER ASTM B-36  
SLEEVE - PVC, COLOR - BLUE

23.39 [.921]	18.95 [.746]	3.81-6.35 [.150-.250]	100	LOOSE PIECE, BOX	9-52956-1
22.15 [.872]	17.70 [.697]	3.00-4.90 [.118-.193]	100	LOOSE PIECE, BOX	7-52956-1
23.39 [.921]	18.95 [.746]	3.81-6.35 [.150-.250]	2500	ON TAPE, REEL	52956-3
23.39 [.921]	18.95 [.746]	3.81-6.35 [.150-.250]	1000	LOOSE PIECE	52956-2
22.15 [.872]	17.70 [.697]	3.00-4.90 [.118-.193]	5000	ON TAPE, REEL	52956-1
22.15 [.872]	17.70 [.697]	3.00-4.90 [.118-.193]	1000	LOOSE PIECE	52956
L	E	WIRE INSUL DIA	QTY	PACKAGE TYPE	PART NO

**AMP INCORPORATED  
CUSTOMER SERVICE SYSTEMS**

FOR ADDITIONAL PRODUCT INFORMATION OR COPIES OF DRAWINGS AND TECHNICAL DOCUMENTS  
 PRODUCT INFORMATION CENTER  
 1-800-522-6752

FOR APPLICATION TOOLING ASSISTANCE CENTER  
 TOOLING INFORMATION  
 1-800-722-1111

FOR ORDER ENTRY  
 1-800-526-5142

MAX RECOMMENDED OPERATING TEMPERATURE:  
 105°C [221° F]

VOLTAGE RATING:  
 600V MAX  
 (1000V FIXTURE OR SIGN)

CIRCULAR MIL AREA:  
 1.04-2.62mm² [2,050-5,180]  
 SOLID OR STRANDED

THIS DRAWING IS A CONTROLLED DOCUMENT FOR AMP INCORPORATED. IT IS SUBJECT TO CHANGE AND THE CONTROLLING ENGINEERING ORGANIZATION SHOULD BE CONTACTED FOR THE LATEST REVISION.

THIS DRAWING IS A CONTROLLED DOCUMENT.

DIMENSIONS: mm [INCHES]

TOLERANCES UNLESS OTHERWISE SPECIFIED:

0 PLC	± -
1 PLC	± -
2 PLC	± 0.20 [.008]
3 PLC	± -
4 PLC	± -
ANGLES	± -

MATERIAL: TIN PER ASTM B545

DWN L OLMEDA 26JUN95  
 CHK M ELLIS 26JUN95  
 APVD G NGO 26JUN95

**tyco Electronics** Tyco Electronics Corporation  
 Harrisburg, Pa 17105-3608

NAME: TERMINAL, SPRING SPADE, SHORT, PLASTI-GRIP, WIRE SIZE: 16-14

PRODUCT SPEC: UL 486A

APPLICATION SPEC: -

WEIGHT: -

SIZE: A3 CAGE CODE: 00779 DRAWING NO: C-52956 RESTRICTED TO: -

CUSTOMER DRAWING SCALE: 6:1 SHEET: 1 OF 1 REV: M